

# GBT SERIES

## CASED CEILING MOUNT HYDRONIC HEAT DX COIL AIR HANDLER

### Product Dimensions & Specifications

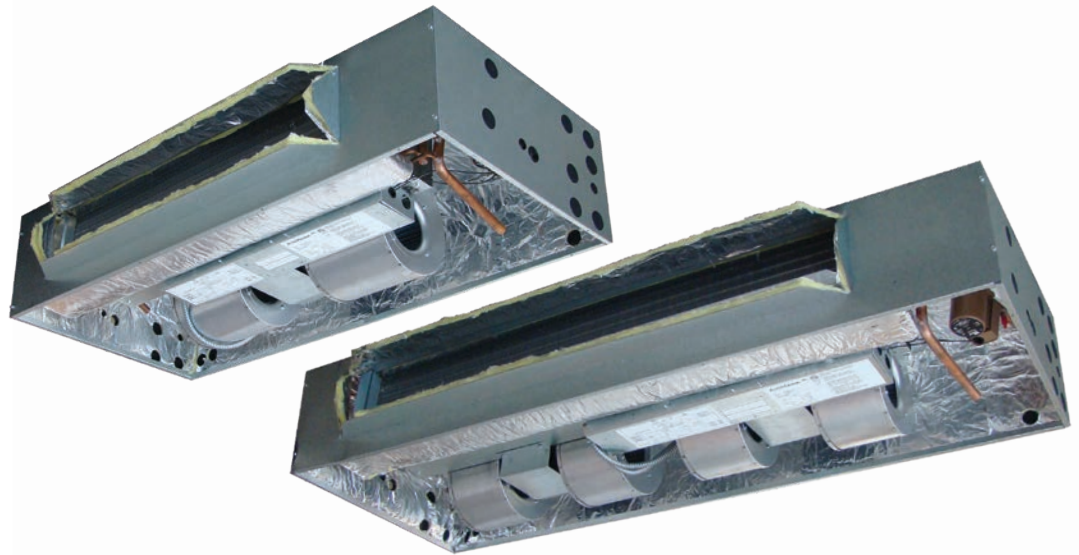

#### WARRANTY

One year limited parts warranty

#### OPTIONS

See options menu

#### MANUFACTURED IN THE USA

#### STANDARD FEATURES

- Factory installed service switch
- Factory installed freeze protection
- Rifled copper tube/enhanced aluminum fins DX and hydronic coils for more efficient heat transfer
- Schrader valve on DX and hydronic coils for “hiss-test” leak check
- Low leak cabinet design\*

#### APPLICATION VERSATILITY

Built-in mounting tabs for ceiling or furdawn mounting. Compatible with most brands of air conditioners and heat pumps. Optional louvered ceiling access panel has separate frame that attached to ceiling joists. Optional solid ceiling panel available for use with ducted return. Less than 2% air leakage (\* when tested in accordance with ASHRAE standard 193 and AirMark installation instructions.) Fully insulated galvanized steel cabinet with knockout for ducted return.

#### MOTOR

Direct drive blowers circulate air quietly and efficiently. Multiple speeds allow for precise air volume selection. Air moving system is plated mounted to allow for easy removal and service.

#### ELECTRONIC CONTROLS

Electronic board controls the functioning of system, increasing system reliability. Standard factory installed freeze stat wired into circulating pump control circuit. Standard factory installed fan time delay relay for increased efficiency and maximize capacity. Standard factory installed pump cycle timer circulates hot water every four hours to prevent coil freeze during off-cycle.

#### DX/HYDRONIC COILS

High efficiency rifled copper tube and enhanced aluminum fins provide maximum heat transfer. All coils are immersion tested at 500 PSI and nitrogen charged for maximum reliability. Schrader valve allows for “hiss-test” pre-installation pressure test. Available with factory installed orifice or TXV. Primary and secondary DX condensate drain with 3/4” NPT connections. Powder-painted galvanized drain pan. Certified for use with R22 or R410A. Lead free construction. Hydronic coils suitable for potable water applications.

Representative image only.

Some models may vary in appearance.

Due to continuous product improvement, specifications are subject to change without notice.



Rev. Date: 03/08/19

© 2019 AirMark



## HEATING AND COOLING PERFORMANCE & ELECTRICAL DATA

MODEL	PERFORMANCE DATA					
	NOMINAL COOLING (BTUS)	HEATING GPM	PRESS. DROP (FT. WTR)	BTU (1000) AT ENTERING WATER TEMPERATURE °F		
				120	140	180
GBT 18	18,000	1	0.7	10.3	14.4	22.6
		2	2.0	12.0	16.8	26.4
		3	3.3	12.9	18.0	28.3
GBT 19/24	24,000	2	2.1	14.7	20.6	32.4
		3	4.1	15.9	22.2	34.9
		4	6.6	16.5	23.1	36.3
GBT 25	24,000	2	2.2	15.7	22.0	34.6
		3	4.3	17.0	23.8	37.4
		4	6.8	17.6	24.7	38.8
GBT 30	30,000	2	2.2	17.3	24.2	38.0
		3	4.3	18.8	26.3	41.3
		4	6.8	19.6	27.5	43.2
GBT 31/36	36,000	2	2.8	19.7	27.6	43.4
		3	5.4	21.7	30.4	47.8
		4	8.5	22.8	31.9	50.1

NOTES: Heat BTUH is at 70 degree EAT. 120 degree and 180 degree data is supplied for boiler applications. Heat BTUH output will not exceed output of water heater.

## BLOWER DATA

UNIT MODEL	RPM	AMP	VOLT	HP	CFM VS. STATIC PRESSURE				
					0.1	0.2	0.3	0.4	0.5
GBT 18	HIGH	2.5	120	1/4	820	750	685	615	540
	LOW				715	670	610	555	460
GBT 19/24	HIGH	2.5		1/4	890	825	755	675	605
	LOW				765	715	665	605	520
GBT 25	HIGH	3.8		1/3	975	900	830	745	680
	LOW				900	840	770	690	620
GBT 30	HIGH	2.3		1/5 (2)	1055	965	865	755	605
	LOW				1015	915	815	705	565
GBT 31/36	HIGH	2.3		1/5 (2)	1235	1150	1040	925	830
	LOW				1050	980	900	800	680

Units should not be applied to a system with less than 350 CFM/Ton airflow.

Add 0.05 static when enclosure and/or ceiling panel are used.

GBT 30, GBT 31 and GBT 36 have two motors and four blowers.

## AIR HANDLER CHASSIS NOMENCLATURE

G	B	T	18	G	-001
AirMark Air Handler	<u>Voltage</u> B = 120V PSC Motor	<u>Configuration</u> T = Cased Ceiling Mount	Nominal Tonnage (KBTUH)	<u>Metering Device</u> 4 = R410A non-bleed A/C or H/P TXV 6 = R410A 20% bleed A/C or H/P TXV B = R22 20% bleed A/C or H/P TXV F = R22 Flo-rater G = R410A Flo-rater X = R22 non-bleed A/C or H/P TXV	Option Code

## HYDRONIC HEAT KIT NOMENCLATURE

Z	T	2	S	P
Water Heat Hydronic	Terminal Block	2 = 2 Row Hydronic Coil	GBT 18 - X GBT 19/24 - S GBT - 25/30 - M GBT 31/36 - L	P = Taco 006 Bronze Pump 8 = Taco 008 Bronze Pump L = Less Pump

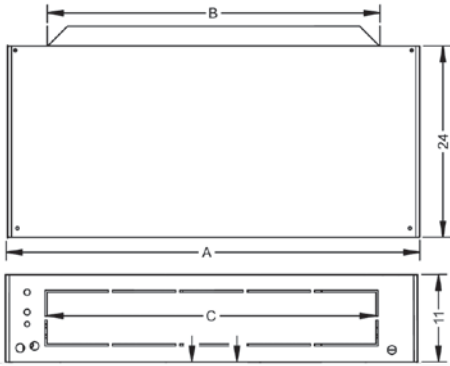

ENCLOSURE DIMENSIONS					
UNIT MODEL	A"	B"	C"	Weight (lbs)	Skid Qty.
GBT 18	46	30	34	110	5
GBT 19-24	52	36	40	125	5
GBT 25	60	42	47	135	5
GBT 30	60	42	47	155	4
GBT 31-36	67	48	55	165	4

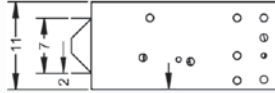

Copper stub out diameter: DX - Suction: 3/4", Liquid: 3/8";  
Hydronic – Water In/Out: 7/8"

## Access Door

### VERSATILITY

Equipped with hidden frame feature. Fastens to the outside wall surface and does not have to perfectly match the hole opening. Frame screws are not visible after installation. Available in either solid (S) or louvered (L) style.

### MATERIALS

Galvanized steel construction with smooth powder paint finish.

### FILTER

20" x 20" x 1" field supplied.

### WARRANTY

One-year limited parts warranty.

ACCESS DOOR DIMENSIONS						
FOR USE WITH	PANEL MODEL	GBT ACCESS DOOR AND FRAME				FILTERS (QTY)
		A"	B"	C"	D"	
GBT 18	GAD-7(S/L)	49 1/2	27 1/2	47 1/2	26	1
GBT 19/24	GAD-3(S/L)	55 1/2	27 1/2	53 1/2	26	1
GBT 25/30	GAD-6(S/L)	63-1/2	27 1/2	61-1/2	26	2
GBT 31/36	GAD-4(S/L)	70-1/2	27 1/2	68-1/2	26	2

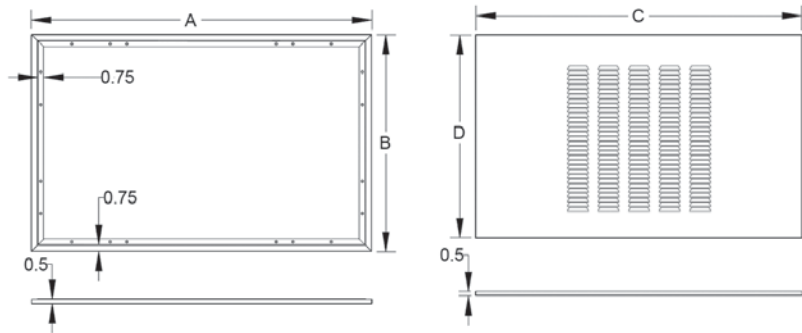

CAP KIT PART NUMBER		
Part Number	Model Number	Enclosure Size
CAP-5	GBT18	46"X24"X11"
CAP-6	GBT19/24	52"X24"X11"
CAP-7	GBT25/30	60"X24"X11"
CAP-8	GBT31/36	67"X24"X11"

Note: CAP kit is an insulated panel that covers the entire bottom opening and is utilized for optional ducted return configuration



373 Atascocita Rd  
Humble, TX 77396  
Phone 800.423.9007  
Fax 281.441.6510  
[www.airmark-ac.com](http://www.airmark-ac.com)

**WARNING**  
Cancer and  
Reproductive Harm  
[www.P65Warnings.ca.gov](http://www.P65Warnings.ca.gov)