

GET SERIES

HIGH EFFICIENCY ECM CASED CEILING MOUNT ELECTRIC HEAT DX COOL AIR HANDLER

Product Dimensions & Specifications



WARRANTY

One year limited parts warranty

OPTIONS

See options menu

MANUFACTURED IN THE USA

STANDARD FEATURES

APPLICATION VERSATILITY

Built in mounting tabs for ceiling or furrdown mounting. Louvered ceiling access panel has separate frame that attaches to ceiling joists. Solid access panel available for use with end return installations. Compatible with most brands of air conditioners or heat pumps.

MOTOR

Constant torque ECM allows motor speed control with embedded software. Motors are pre-programmed at the factory.

LOW LEAKAGE CABINET

Less than 2% air leakage from cabinet when tested in accordance with ASHRAE standard 193. Unit must be installed according to AirMark installation instructions. Sturdy, fully insulated galvanized steel cabinet with knockout for duct return.

ELECTRONIC CIRCUIT BOARD

Electronic circuit board provides 30 secs ON/OFF blower time delay extracting more heat/cool from the coil.

ELECTRIC HEAT KITS

Heat kits available in 3, 5, 6, 8, & 10 KW. Models with electric heat include sequencers and temperature limit switches for safe, efficient operation. Easily accessible controls for quick service.

DX COIL

High efficiency rifled copper tube/enhanced aluminum fins provide maximum heat transfer. All coils immersion tested at 500 psi then nitrogen pressurized and factory sealed for maximum reliability. Liquid-line Schrader allows pre-installation pressure testing. Available with either orifice or TXV metering device factory installed. Field-installable bolt-on TXVs is also available. Primary & secondary condensate drain. All drain connections are 3/4" NPT. Powder-painted metal drain pan. Access door allows for coil cleaning. Certified for use with either R22 or R410A.

Representative image only.
Some models may vary in appearance.
Due to continuous product improvement,
specifications are subject to change
without notice.



Rev. Date: 01/13/20

© 2021 AirMark



HEATING AND COOLING PERFORMANCE AND ELECTRICAL DATA

MODEL	HEAT KIT	PERFORMANCE DATA				ELECTRICAL DATA				
		NOMINAL COOLING (BTUS)	HEATING KW		HEATING KBTUH		MINIMUM CIRCUIT AMPACITY (MCA)		MAX BREAKER OR FUSE SIZE	
			208V	240V	208V	240V	208V	240V	208V	240V
GET 18/19/20	HTS00	18,000	0.0	0.0	0.0	0.0	5.0	5.0	15.0	15.0
	HTS03		2.3	3.0	7.8	10.2	18.5	20.6	20.0	20.0
	HTS05		3.7	4.8	12.6	16.4	26.6	30.0	30.0	30.0
	HTS06		4.6	6.0	15.7	20.5	32.0	36.3	35.0	40.0
	HTS08		6.1	8.0	20.8	27.3	41.1	46.7	45.0	50.0
	HTS10		7.4	9.6	25.3	32.8	48.3	55.0	50.0	60.0
GET 24/25/26/28	HTS00	24,000	0.0	0.0	0.0	0.0	5.0	5.0	15.0	15.0
	HTS03		2.3	3.0	7.8	10.2	18.5	20.6	20.0	20.0
	HTS05		3.7	4.8	12.6	16.4	26.6	30.0	30.0	30.0
	HTS06		4.6	6.0	15.7	20.5	32.0	36.3	35.0	40.0
	HTS08		6.1	8.0	20.8	27.3	41.1	46.7	45.0	50.0
	HTS10		7.4	9.6	25.3	32.8	48.3	55.0	50.0	60.0
GET 30/31/32	HTS00	30,000	0.0	0.0	0.0	0.0	5.0	5.0	15.0	15.0
	HTS03		2.3	3.0	7.8	10.2	18.5	20.6	20.0	20.0
	HTS05		3.7	4.8	12.6	16.4	26.6	30.0	30.0	30.0
	HTS06		4.6	6.0	15.7	20.5	32.0	36.3	35.0	40.0
	HTS08		6.1	8.0	20.8	27.3	41.1	46.7	45.0	50.0
	HTS10		7.4	9.6	25.3	32.8	48.3	55.0	50.0	60.0
GET 36/37	HTS00	36,000	0.0	0.0	0.0	0.0	5.0	5.0	15.0	15.0
	HTS03		2.3	3.0	7.8	10.2	18.5	20.6	20.0	20.0
	HTS05		3.7	4.8	12.6	16.4	26.6	30.0	30.0	30.0
	HTS06		4.6	6.0	15.7	20.5	32.0	36.3	35.0	40.0
	HTS08		6.1	8.0	20.8	27.3	41.1	46.7	45.0	50.0
	HTS10		7.4	9.6	25.3	32.8	48.3	55.0	50.0	60.0

AIR HANDLER CHASSIS NOMENCLATURE

G	E	T	18	G	-001
AirMark Air Handler	<u>Voltage & Motor</u> E = 208- 240V Constant Torque ECM	<u>Configuration</u> T = Cased Ceiling Mount	Nominal Tonnage (KBTUH)	<u>Metering Device</u> 4 = R410A non-bleed A/C or H/P TXV 6 = R410A 20% bleed A/C or H/P TXV B = R22 20% bleed A/C or H/P TXV F = R22 Flo-rater G = R410A Flo-rater X = R22 non-bleed A/C or H/P TXV	Option Code

ELECTRIC HEAT KIT NOMENCLATURE

H	T	S	10
H = Fits GAS, GAT, GES, GET	T = Terminal Block	S = Small Cabinet (18 - 37)	<u>Heat Strip</u> 00 = NO Heat 03 = 3 KW 05 = 5 KW 06 = 6 KW 08 = 8 KW 10 = 10 KW

BLOWER DATA

UNIT MODEL	SPEED TAP	MOTOR HP	BHP	CFM VS. STATIC PRESSURE									
				0.05	0.1	0.15	0.2	0.25	0.3	0.35	0.4	0.45	0.50
GET 18/19	T5*	1/2	0.27	925	900	875	850	830	805	785	765	705	650
	T4		0.20	855	840	825	805	785	760	732.5	705	650	595
	T3		0.18	825	805	785	760	735	705	685	665	615	565
	T2		0.14	725	705	685	665	640	615	600	580	535	495
	T1		0.10	680	655	630	605	580	555	530	500	465	425
GET 20/24	T5*		0.28	950	925	900	875	850	825	800	770	710	655
	T4		0.20	885	860	835	805	775	745	725	705	650	600
	T3		0.20	855	825	795	765	735	705	680	655	600	550
	T2		0.18	790	765	740	715	685	655	630	605	560	515
	T1		0.14	735	705	675	650	630	605	580	555	510	470
GET 25	T5*		0.31	1000	975	950	925	900	875	855	835	775	710
	T4		0.28	940	915	890	865	840	815	800	780	720	660
	T3		0.21	885	865	845	825	805	780	755	730	675	620
	T2		0.20	825	805	785	760	730	695	675	655	605	560
	T1		0.14	755	730	705	675	645	615	590	565	525	480
GET 26/31	T5*	0.35	1205	1180	1155	1130	1100	1070	1045	1015	930	860	
	T4	0.31	1145	1115	1085	1060	1040	1015	985	950	880	810	
	T3	0.29	1045	1015	985	950	925	900	880	860	800	730	
	T2	0.22	940	910	880	850	825	795	770	745	680	630	
	T1	0.20	850	815	780	745	715	685	665	640	590	545	
GET 28/32	T5*	0.45	1245	1220	1195	1165	1140	1115	1090	1060	980	900	
	T4	0.35	1160	1140	1120	1100	1080	1060	1030	1000	925	850	
	T3	0.31	1035	1010	985	965	940	910	885	860	800	730	
	T2	0.27	895	885	875	860	820	775	755	735	680	625	
	T1	0.25	840	815	790	765	735	705	685	665	615	565	
GET 30/36	T5*	0.42	1220	1195	1170	1140	1115	1085	1065	1050	970	890	
	T4	0.33	1140	1115	1090	1060	1040	1015	990	965	894	820	
	T3	0.27	1025	1000	975	950	925	895	875	850	785	725	
	T2	0.25	950	920	890	860	835	805	775	745	690	630	
	T1	0.23	840	815	790	760	730	700	670	640	590	545	
GET 37	T5*	0.48	1335	1305	1285	1255	1225	1195	1160	1130	1045	960	
	T4	0.31	1260	1230	1195	1165	1140	1115	1090	1070	990	910	
	T3	0.29	1160	1130	1110	1085	1065	1040	1020	1000	925	850	
	T2	0.27	1075	1045	1010	980	960	935	920	900	830	765	
	T1	0.21	965	935	910	885	850	810	795	775	715	650	

* Default factory speed setting

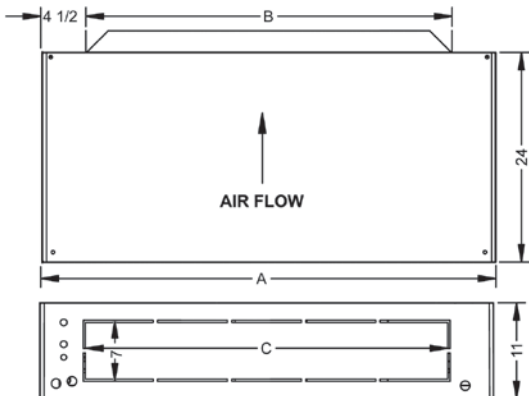

ENCLOSURES DIMENSIONS					
UNIT MODEL	A"	B"	C"	Weight (lbs)	Skid Qty.
GET 18/19/24	40	30	30	135	5
GET 20/25	46	36	36	145	5
GET 26/30/31/36	52	42	42	155	5
GET 28/32/37	60	48	48	175	5

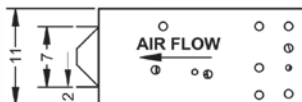

Copper stub out diameter: Suction: 3/4", Liquid: 3/8"

KNOCKOUT FOR DUCTED RETURN

(Ducted return requires remote filter grille (field supplied) and non-louvered panel)

Access Door

VERSATILITY

Equipped with hidden frame feature. Fastens to the outside wall surface and does not have to perfectly match the hole opening. Frame screws are not visible after installation. Available in either solid (S) or louvered (L) style.

MATERIALS

Galvanized steel construction with smooth powder paint finish.

FILTER

20" x 20" x 1" field supplied.

WARRANTY

One-year limited parts warranty.

ACCESS DOOR DIMENSIONS						
FOR USE WITH	PANEL MODEL	GET ACCESS DOOR AND FRAME				FILTERS (QTY)
		A"	B"	C"	D"	
GET 18/19/24	GAD-1(S/L)	43-1/2	27-1/2	41-1/2	26	1
GET 20/25	GAD-5(S/L)	49-1/2	27-1/2	47-1/2	26	2
GET 26/30/31/36	GAD-2(S/L)	55-1/2	27-1/2	53-1/2	26	2
GET 28/32/37	GAD-6(S/L)	63-1/2	27-1/2	61-1/2	26	2

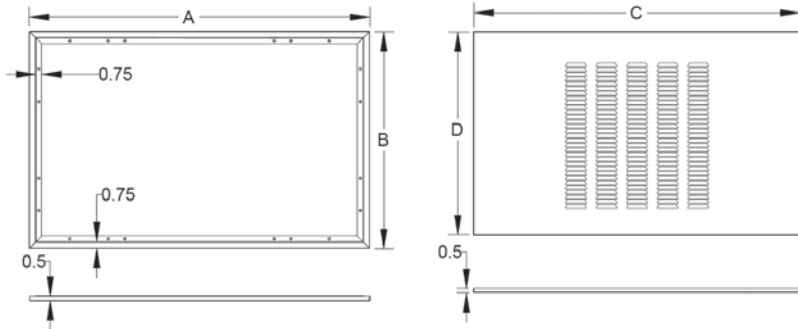

CAP KIT PART NUMBER		
Part Number	Model Number	Enclosure Size
CAP-1	GET18/19/24	40"X24"X11"
CAP-2	GET20/25	46"X24"X11"
CAP-3	GET 26/30/31/36	52"X24"X11"
CAP-4	GET 28/32/37	60"X24"X11"

Note: CAP kit is an insulated panel that covers the entire bottom opening and is utilized for optional ducted return configuration



373 Atascocita Rd
 Humble, TX 77396
 Phone 800.423.9007
 Fax 281.441.6510
www.airmark-ac.com

⚠ WARNING
Cancer and
Reproductive Harm
www.P65Warnings.ca.gov